

Pressed branch saddle with gasket

SPL



Description

Pressed saddles are designed for fabricating ventilation duct T-pieces. They can also be used as splices for branching the main round ventilation ducts with round SPIRAL ducts, FLX flexible ducts, or sonoducts. The rounding radius of the branch base improves the air flow, ensuring better energy efficiency of ventilation, and the end with an EPDM gasket meets requirements of air tightness class D according to EN 12237. The piece can be used with several different diameter sizes, as shown in the selection table.

Available materials — Product code example

SPL-... -... – galvanized steel sheet

Product code example

Product code: **SPL - aaa - bbb**

type _____
 $\text{Ø}d_1$ _____
 $\text{Ø}d_3$ _____

Dimensions

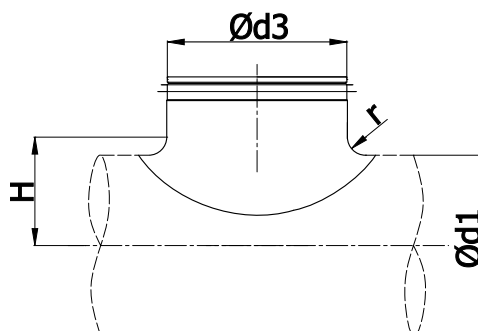

$\text{Ø}d_{1, \text{nom}} - \text{Ø}d_{3, \text{nom}}$ [mm]	diameter range for $\text{Ø}d_{1, \text{nom}}$ [mm]	r [mm]	H [mm]	Weight [kg]
80-80		10	50	0,1
100-80	100 - 112	10	60	0,1
125-80	112 - 125 - 140	10	72	0,1
160-80	150 - 160	10	90	0,1
200-80	180 - 200	10	110	0,1
250-80	224 - 250 - 280	10	135	0,1
	300 - 315			
100-100		12	62	0,2
125-100	112 - 125 - 140	12	74	0,2
160-100	150 - 160	12	92	0,2
200-100	180 - 200	12	112	0,2
250-100	224 - 250	12	137	0,2
315-100	280 - 300 - 315 - 355	12	169	0,2
500-100	400 - 450 - 500 - 560	12	262	0,2
125-125		12	74	0,3
160-125	140 - 150 - 160	12	92	0,3
200-125	180 - 200	12	112	0,3
250-125	224 - 250	12	137	0,2
315-125	280 - 300 - 315 - 355	12	169	0,2
500-125	400 - 450 - 500 - 560	12	262	0,2
200-150	180 - 200	12	112	0,3
250-150	224 - 250	12	137	0,3
315-150	280 - 300 - 315 - 355	12	169	0,3
160-160		16	96	0,4
200-160	180 - 200	16	116	0,4
250-160	224 - 250	16	141	0,4
315-160	280 - 300 - 315	16	173	0,3
400-160	355 - 400	16	216	0,3
500-160	400 - 450 - 500 - 560	16	266	0,3
200-200		20	120	0,5
250-200	224 - 250	20	145	0,5
315-200	280 - 300 - 315	20	177	0,5
400-200	355 - 400	20	220	0,5
500-200	400 - 450 - 500 - 560	20	270	0,3

Pressed branch saddle with gasket

SPL**Dimensions**

$\varnothing d_{1\text{nom}} - \varnothing d_{3\text{nom}}$ [mm]	diameter range for $\varnothing d_{1\text{nom}}$ [mm]	r [mm]	H [mm]	Weight [kg]
250-250		20	145	0,7
315-250	280 - 300 - 315	20	177	0,7
400-250	355 - 400	20	220	0,7
500-250	400 - 450 - 500 - 560	20	270	0,5
315-315		20	177	0,7
400-315	355 - 400 - 450	20	220	0,8
500-315	400 - 450 - 500 - 560	25	275	0,8
500-400	400 - 450 - 500 - 560	30	280	1,0