

45° branch T-pieces and X-pieces

TSVL/TSV-45 XSVL/XSV-45

TSVL-45



Description

T-pieces and X-pieces are ventilation system components for SPIRAL ducts and other fittings. The branch port and the branch duct can be of equal or smaller diameter than the main duct. The branch port can be angled at 15, 30, 45 or 60 degrees, or any other requested angle. The selection of various configurations allows building branches without an unnecessary increase of flow resistance.

- TSVL-45** - T-piece with an EPDM gasket (air tightness class D) and a 45° branch port. Available on request: 15°, 30°, 60°, e.g. TSVL 15° - d₁ - d₃
- TSV-45** - T-piece without a gasket, with a 45° branch port. Available on request: 15°, 30°, 60°, e.g. TSV 15° - d₁ - d₃
- XSVL-45** - four-way piece with an EPDM gasket (air tightness class D) and a 45° branch port. Available on request: 15°, 30°, 60°, e.g. XSVL 15° - d₁ - d₃ - d₄
- XSV-45** - four-way piece without a gasket, with a 45° branch port. Available on request: 15°.

Available materials - Product code example

- TSVL-45-... -... - galvanized steel sheet
- TSVL-45-K-...-... - 1.4301/304 stainless steel sheet
- TSVL-45-K-...-...-316L - 1.4404/316L stainless steel sheet, molybdenum-enriched
- TSVL-45-A-...-... - AW-1050A H24 aluminium sheet
- TSVL-45-CU-...-... - M1E z4 copper sheet
- TSVL-45-ZM-...-... - ZM310 coating (only up to a diameter of Ød₁ = 500mm)

Product code example

Product code: **TSVL-45 - aaa - bbb**

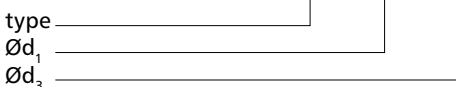

XSVL-45



Dimensions

TSV-45

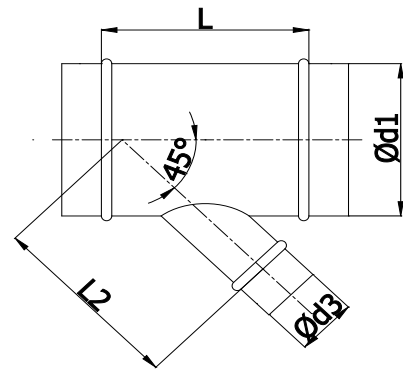

XSVL-45

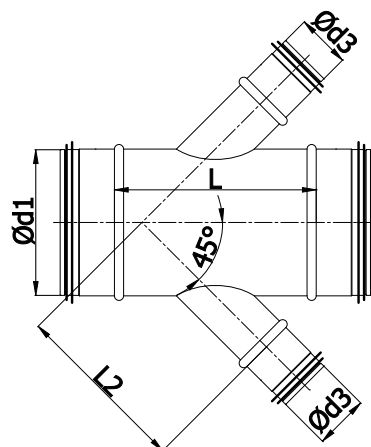

45° branch T-pieces and X-pieces

TSVL/TSV-45 XSVL/XSV-45

Dimensions

Ød ₁ [mm]	Ød ₃ [mm]	L [mm]	L ₂ [mm]	Weight [kg]	
				TSVL/TSV	XSVL/XSV
80	80	185	120	0.4	0.5
100	80	185	140	0.4	0.5
	100	210	150	0.5	0.6
125	80	185	160	0.5	0.6
	100	210	170	0.6	0.7
	125	250	180	0.7	0.9
140	80	185	170	0.6	0.7
	100	215	180	0.7	0.8
	125	250	190	0.8	0.9
	140	270	200	0.9	1.0
150	80	185	180	0.6	0.7
	100	215	190	0.7	0.8
	125	250	200	0.8	1.0
	140	270	210	0.9	1.1
	150	285	210	0.9	1.2
160	80	185	180	0.6	0.7
	100	215	190	0.7	0.9
	125	250	200	0.8	1.0
	140	270	210	0.9	1.1
	150	285	220	1.0	1.2
	160	300	220	1.0	1.3
180	80	185	200	0.7	0.8
	100	215	210	0.8	0.9
	125	250	220	0.9	1.1
	140	270	230	1.0	1.2
	150	285	230	1.0	1.3
	160	300	240	1.1	1.4
	180	325	250	1.2	1.5
200	80	185	210	0.8	0.9
	100	215	220	0.9	1.0
	125	250	230	1.0	1.2
	140	270	240	1.0	1.3
	150	285	250	1.1	1.4
	160	300	250	1.2	1.5
	180	325	260	1.3	1.6
	200	355	270	1.4	1.8
224	100	215	240	1.0	1.1
	125	250	250	1.1	1.3
	140	270	260	1.2	1.4
	150	285	260	1.2	1.5
	160	300	270	1.3	1.6
	180	325	280	1.4	1.7
	200	355	290	1.5	1.9
	224	390	300	1.7	2.2

Ød ₁ [mm]	Ød ₃ [mm]	L [mm]	L ₂ [mm]	Weight [kg]	
				TSVL/TSV	XSVL/XSV
250	100	215	260	1.2	1.3
	125	250	270	1.3	1.5
	140	270	280	1.4	1.6
	150	285	280	1.5	1.7
	160	300	290	1.5	1.8
	180	325	300	1.7	2.0
	200	355	310	1.8	2.2
	224	390	320	2.0	2.4
	250	440	330	2.3	2.9
280	125	250	290	1.5	1.6
	140	270	300	1.6	1.8
	150	285	300	1.6	1.9
	160	300	310	1.7	2.0
	180	325	320	1.8	2.1
	200	355	330	2.0	2.3
	224	390	340	2.2	2.6
	250	440	350	2.5	3.0
	280	480	370	2.7	3.4
300	125	250	300	1.6	1.7
	140	270	310	1.6	1.8
	150	285	320	1.7	2.0
	160	300	320	1.8	2.0
	180	325	330	1.9	2.2
	200	355	340	2.1	2.4
	224	390	350	2.3	2.7
	250	440	370	2.6	3.1
	280	480	380	2.8	3.5
	300	510	390	3.1	3.8
315	140	270	320	1.7	1.9
	150	285	330	1.8	2.0
	160	300	330	1.9	2.1
	180	325	340	2.0	2.3
	200	355	350	2.2	2.5
	224	390	360	2.4	2.8
	250	440	380	2.7	3.3
	280	480	390	3.0	3.6
	300	510	400	3.2	3.9
	315	530	410	3.3	4.1

45° branch port T-pieces and X-pieces

TSVL/TSV-45 XSVL/XSV-45**Dimensions**

Ød ₁ [mm]	Ød ₃ [mm]	L [mm]	L ₂ [mm]	Weight [kg]	
				TSVL/TSV	XSVL/XSV
355	150	285	350	2.4	2.7
	160	300	360	2.5	2.8
	180	325	370	2.7	3.0
	200	355	380	2.9	3.3
	224	390	390	3.1	3.6
	250	440	400	3.5	4.2
	280	480	420	3.9	4.7
	300	510	430	4.1	5.0
	315	530	440	4.3	5.2
	355	585	460	4.8	6.0
400	160	300	390	3.0	3.3
	180	325	400	3.2	3.6
	200	355	410	3.4	3.8
	224	390	420	3.7	4.2
	250	440	440	4.2	4.8
	280	480	450	4.5	5.2
	300	510	460	4.8	5.6
	315	530	470	5.0	5.9
	355	585	490	5.5	6.6
	400	650	510	6.3	7.8
450	180	325	440	4.2	4.6
	200	355	450	4.5	4.9
	224	390	460	4.8	5.4
	250	440	470	5.4	6.1
	280	480	490	5.8	6.7
	300	510	500	6.1	7.1
	315	530	500	6.4	7.4
	355	585	520	7.0	8.3
	400	650	550	8.0	9.7
	450	740	570	9.0	11.2
500	200	355	480	4.9	5.3
	224	390	490	5.3	5.8
	250	440	510	5.9	6.6
	280	480	520	6.4	7.2
	300	510	530	6.7	7.6
	315	530	540	6.9	7.9
	355	585	560	7.6	8.9
	400	650	580	8.6	10.3
	450	740	610	9.7	11.8
	500	810	630	10.8	14.3

Ød ₁ [mm]	Ød ₃ [mm]	L [mm]	L ₂ [mm]	Weight [kg]	
				TSVL/TSV	XSVL/XSV
560	224	390	540	5.9	6.4
	250	440	550	6.5	7.2
	280	480	570	7.0	7.8
	300	510	580	7.4	8.3
	315	530	580	7.6	8.7
	355	585	600	8.4	9.6
	400	650	630	9.4	11.0
	450	740	650	10.6	12.6
	500	810	680	11.7	14.1
	560	900	710	13.1	16.1
600	250	440	580	6.9	7.7
	280	480	600	7.5	8.3
	300	510	610	7.9	8.8
	315	530	610	8.1	9.2
	355	585	630	8.9	10.1
	400	650	660	10.0	11.6
	450	740	680	11.2	13.2
	500	810	710	12.3	14.7
	560	900	740	13.8	16.7
	600	960	760	14.8	18.2
630	280	480	620	7.8	8.6
	300	510	630	8.2	9.1
	315	530	630	8.5	9.5
	355	585	650	9.3	10.5
	400	650	680	10.4	12.0
	450	740	700	11.7	13.6
	500	810	730	12.8	15.2
	560	900	760	14.3	17.2
	600	960	780	15.3	18.6
	630	1010	790	16.2	19.8
710	300	510	690	12.5	13.7
	315	530	690	12.9	14.2
	355	585	710	14.0	15.6
	400	650	740	15.6	17.6
	450	740	760	17.4	19.9
	500	810	790	19.0	21.9
	560	900	820	21.0	24.6
	600	960	840	22.4	26.5
	630	1010	850	23.6	28.0
	710	1130	890	27.1	33.0

45° branch port T-pieces and X-pieces

TSVL/TSV-45 XSVL/XSV-45

Dimensions

Ød ₁ [mm]	Ød ₃ [mm]	L [mm]	L ₂ [mm]	Weight [kg]	
				TSVL/TSV	XSVL/XSV
800	315	530	770	14.5	15.8
	355	585	790	15.7	17.3
	400	650	810	17.4	19.5
	450	740	840	19.4	22.0
	500	810	860	21.0	24.0
	560	900	890	23.3	26.9
	600	960	910	24.8	28.9
	630	1010	930	26.0	30.5
	710	1140	970	29.8	35.8
	800	1270	1010	33.7	41.1
900	355	585	860	17.5	19.1
	400	650	890	19.3	21.4
	450	740	910	21.5	24.0
	500	810	940	23.3	26.3
	560	900	970	25.7	29.3
	600	960	990	27.3	31.4
	630	1010	1000	28.7	33.1
	710	1140	1040	32.7	38.6
	800	1270	1090	36.8	44.0
	900	1430	1140	41.8	50.9
1000	400	650	960	21.9	23.9
	450	740	980	24.3	26.7
	500	810	1010	26.3	29.2
	560	900	1040	28.5	32.3
	600	960	1060	30.6	34.5
	630	1010	1070	32.0	36.3
	710	1140	1110	36.3	42.0
	800	1270	1160	40.6	47.7
	900	1430	1210	45.9	54.7
	1000	1590	1260	52.0	62.5
1120	500	810	1090	32.2	35.4
	560	900	1120	35.4	39.1
	600	960	1140	37.5	41.7
	630	1010	1160	39.2	43.8
	710	1140	1200	44.3	50.4
	800	1270	1240	49.4	57.1
	900	1430	1290	55.6	65.1
	1000	1590	1340	62.6	74.6
	1120	1750	1400	70.2	85.3

Ød ₁ [mm]	Ød ₃ [mm]	L [mm]	L ₂ [mm]	Weight [kg]		
				TSVL/TSV	XSVL/XSV	
1250	500	810	1190	35.6	38.7	
	560	900	1220	39.0	42.8	
	600	960	1240	41.3	45.5	
	630	1010	1250	43.2	47.7	
	710	1140	1290	48.6	54.7	
1250	800	1270	1340	54.1	61.7	
	900	1430	1390	60.8	70.1	
	1000	1590	1440	68.2	80.0	
	1120	1750	1490	76.0	90.4	
	1250	1940	1560	85.5	103.7	
	1400	600	960	1350	45.7	49.9
		630	1010	1360	47.8	52.3
		710	1140	1400	53.7	59.7
		800	1270	1440	59.6	67.1
		900	1430	1490	66.8	75.9
1000		1590	1540	74.7	86.3	
1120		1750	1600	82.9	97.1	
1250		1940	1670	92.9	110.5	
1400		2150	1740	104.7	126.8	
1500		630	1010	1430	50.8	53.0
	710	1140	1470	57.0	60.4	
	800	1270	1520	63.4	67.6	
	900	1430	1570	70.9	77.0	
	1000	1590	1620	79.2	87.7	
	1120	1750	1680	87.7	98.6	
	1250	1940	1740	98.0	111.9	
	1400	2150	1820	110.2	128.4	
	1500	2290	1870	118.9	140.6	
	1600	710	1140	1550	60.5	63.9
800		1270	1590	67.2	71.5	
900		1430	1640	75.2	81.2	
1000		1590	1690	83.8	92.3	
1120		1750	1750	92.7	103.5	
1250		1940	1820	103.3	117.0	
1400		2150	1890	115.9	133.9	
1500		2290	1940	124.8	146.0	
1600		2430	1990	134.0	158.7	