

Series
FBK



■ **Applications**

Pocket type air filters are applied for supply air and sometimes extract air purification in round duct ventilating and conditioning systems. Designed for protection of the air ducts, heat exchangers, control equipment and other ventilating equipment against dusting. The filters minimize wall and ceiling pollution near the air diffuser. Coarse filters can be used as first stage purification filters before more efficient filters.

■ **Design**

The casing is made of galvanized steel. The filtering box has connecting flanges with rubber seals for airtight connection to the air ducts. The swing-out door equipped with lever locks provides easy and quick access to the replaceable filtering element. The filtering element is made of non-woven fabric from synthetic fibers and is fixed on the galvanized steel frame. The filters are available in G4, F5, F7 filtering class.

■ **Mounting**

The filter design ensures its mounting on the round ducts in any position by means of clamps. The air flow direction shall match the pointer direction on the filter. Both horizontal and vertical mounting is possible. In case of vertical installation the air shall be streamed downwards in such a way as to avoid pockets crumpling. Access for the filter cleaning or replacement shall be provided.

Overall dimensions:

Type	Dimensions [mm]				Mass, [kg]
	∅D	B	B1	H	
FBK 100	99	210	230	170	2,41
FBK 125	124	220	240	206	2,69
FBK 150	149	270	290	236	3,20
FBK 160	159	270	290	236	3,26
FBK 200	199	320	340	276	3,76
FBK 250	249	370	390	386	4,39
FBK 315	314	430	450	390	5,17

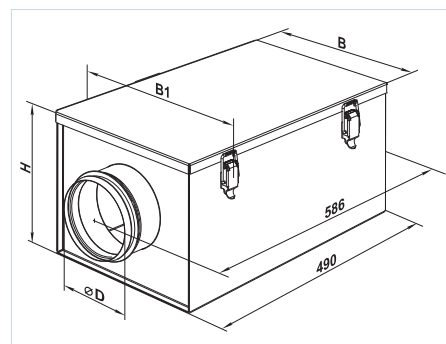

Designation key:

Series	Flange diameter, mm	Filtering class
FBK SFK	100; 125; 150; 160; 200; 250; 315	4 – G4 5 – F5 7 – F7

SFK replaceable filter



